

## Fold Tri-angle System Installation Guide



The Grace Solar Fixed Triangle System is preferred to be installed on the low-profile roof or open ground. The tilt angle can be customized. The AI section can be pre-cut and high pre-assembly on the factory to save your time and money and make the installation more easily.

The installations please follow the procedures and precautions in these instructions carefully. And it must be complied with the local construction acts and the safety laws.

## **1. Introduction**

### 1.1 Intended use

- Are intended to be used by individuals with sufficient technical skills for the task. Knowledge and use of hand tools, measuring devices and values is also required.
- Include various precautions in the forms of Notes, Cautions, and Warnings. These are to assist in the assembly process and/or to draw attention to the fact that certain assembly steps may be dangerous could cause serious personal injury and/or damage to components. Following the step-by-step procedures and these precautions should minimize the risk of any personal injury or damage to components making the installation not only safe but an efficient process.

### 1.2 Service life warranty

Grace Solar provides a warranty of 10 years for the service life of all materials used.

### 1.3 Safety

The following basic safety instructions and warning symbols form an essential part of this manual and are of fundamental importance when handling this product.

- Do not remove or disable any safety devices
- Comply with the relevant safety regulations.
- The presence of a second party who can provide help in the event of an accident is obligatory during the entire installation process.
- Keep a copy of this installation manual in the immediate vicinity of the system.

### 1.4 Responsibilities of the owner/operator

The system operator has the following safety-related responsibilities:

- To ensure that installation of the system is only carried out by individuals with specialist technical knowledge and basic knowledge of mechanical engineering.
- To ensure that those commissioned to perform the work can evaluate their assigned tasks and recognize possible risks.
- To ensure that those commissioned to perform the work are familiar with the system components.
- To ensure that the installation manual is available during installation. The installation manual is an integral part of the product.
- Ensure that the installation manual, and in particular the safety instructions, are read and understood by the relevant personnel before installation.
- Ensure that the permissible operation conditions are observed. Mounting systems is not liable for damage occurring when these conditions are not adhered to.
- Ensure the durability of all connections and the attachment of the system.
- Ensure that suitable lifting gear is used for installation.
- Ensure that only Mounting System components are used when parts need to be replaced. Otherwise any warranty claim is null and void

## 2. Preparation of Installation

### 2.1 Installation site and Foundation

2.1.1 The installation site of the Fixed Triangle System is preferred to be low profile wood structure or concrete roof or open field area. The other conditions please contact us to check the structure.

2.1.2 On the difference installation site, it is difference for the foundation solution.

- a. Wood structure. It is recommended to use the hanger bolt or wood screw to connect the Triangle Bracket with the wood purlin. The hanger bolt size can be M10 or M12 with min 85mm embedment.

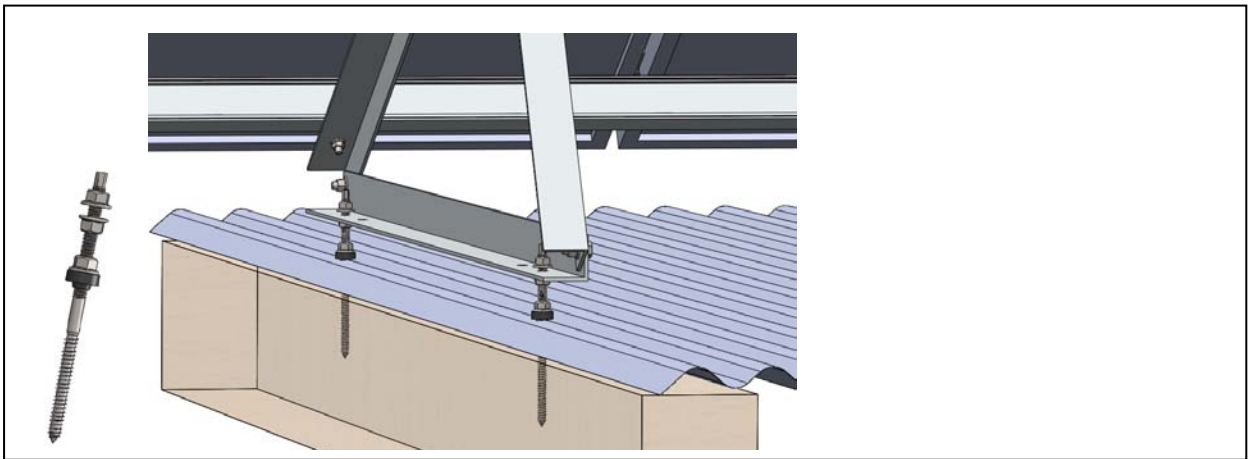

- b. Concrete Roof. It is recommended to use the expand bolt, chemic bolts or pre-buried anchor bolts to connect the Triangle Bracket with the roof. the bolt can be M10 or M12 with min 85mm embedment.

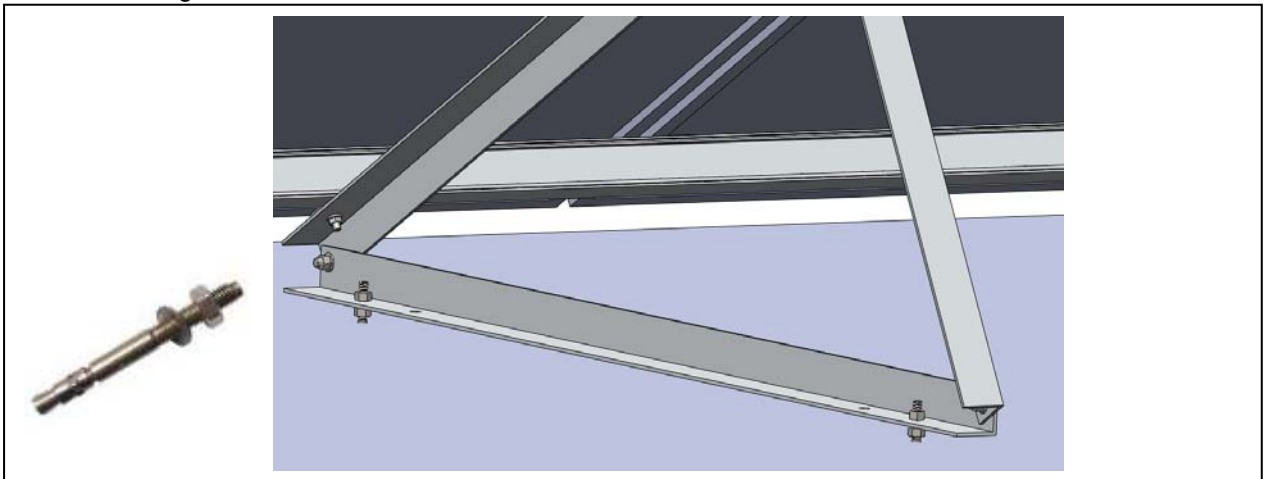

- c. Open field area. Please make a concrete foundation first. Then install the Triangle Bracket on the concrete face as solution b shown.

### 2.1.3 The bottom support dimensions

Please comply with the bottom support spacing to plan the bolt on the foundation. Please note that the dimension of the Triangle Bracket 1# and 2# is difference. The hole on the bottom support is OD12.5.

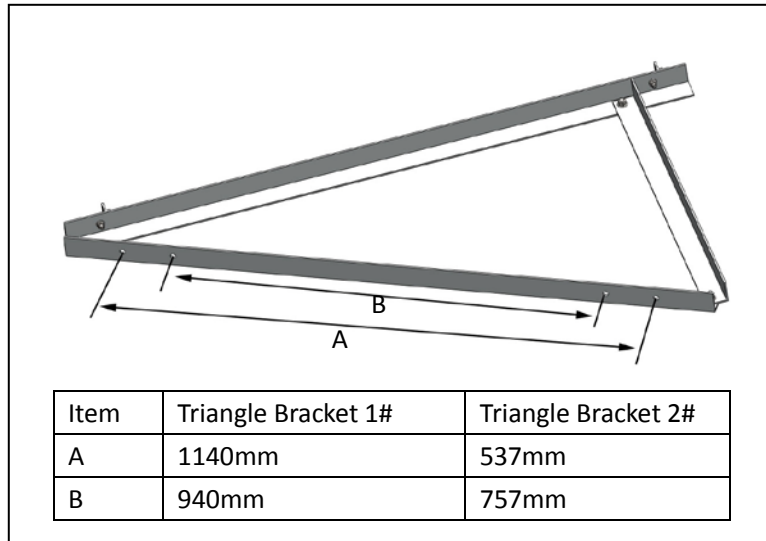

Figure 2.1 Pole Bottom Plate Dimension

2.2 Install Tools

Allen Key 6mm



Coach Wrench  
( for M8~M12 Hex Bolts)



torque Wrench



Tape Measure



1~2 meter level



### 2.3 System overview

The system overview shows all system parts. The scope of supply may vary depending on your order.

Item	Description
1	GD Rail
2	Inter Clamp Kit
3	End Clamp Kit
4	GD Rail Connector
5	Tri-angle Bracket

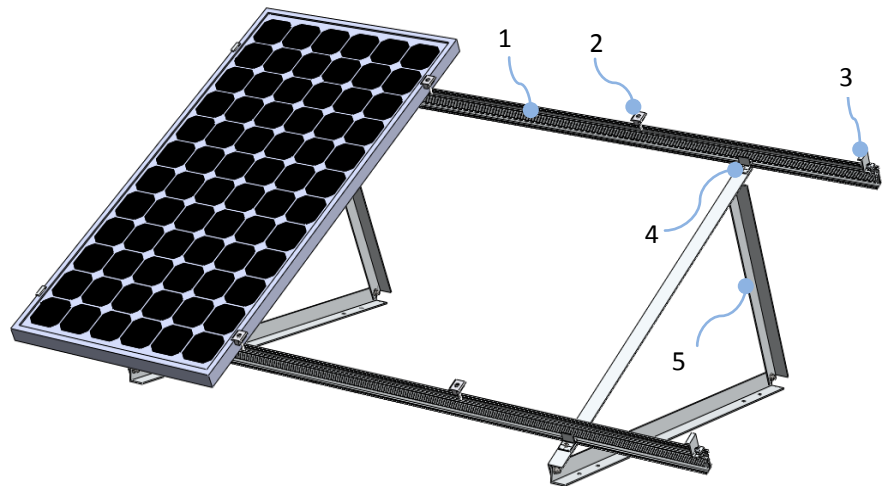
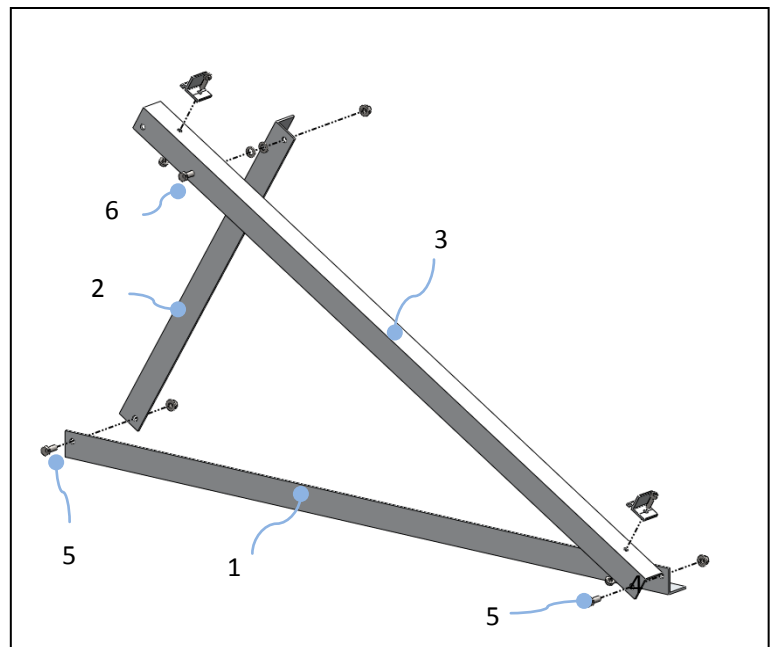

Figure 2.2

### 2.4 Explode View for Triangle Bracket

Item	Description
1	Bottom Support
2	Angle Support
3	Beam
4	GD Rail Connector
5	Hex Bolt M10x25 & Flange Nut M10
6	Hex Bolt M10x25 & Flat Washer x2 & Flange Nut M10



## 2.5 Planning

### 2.5.1 Planning Drawing

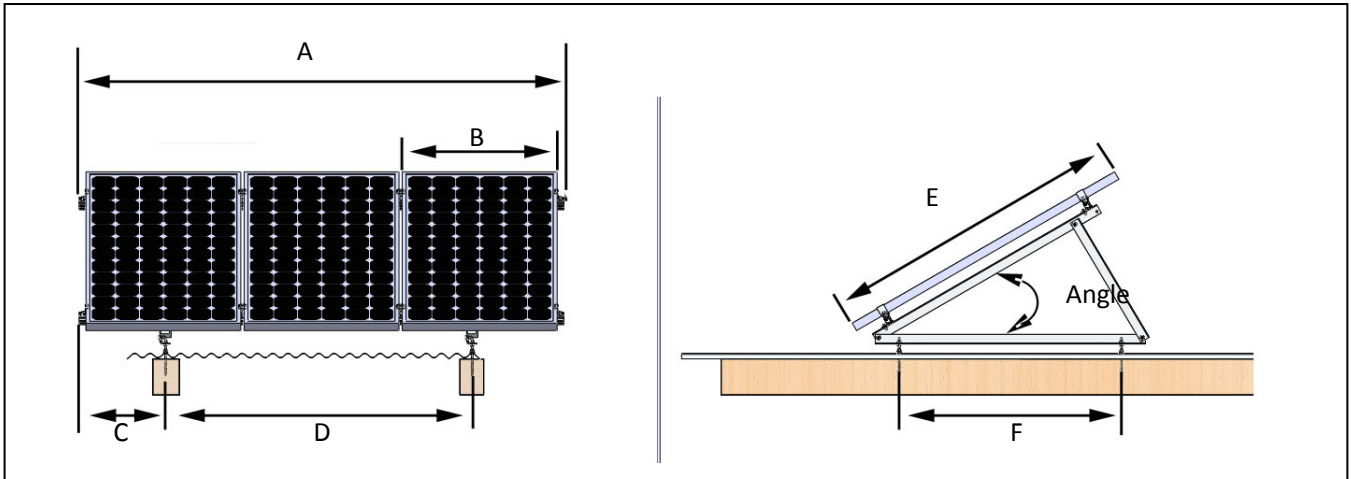

A	Rail Length= (Module width B +18)*Module Qty + 32 mm
B	Module Width
C	Cantilever Length <= Span D / 2
D	Triangle Bracket Span
E	Module Length
F	Foundation Bolts Spacing, Please look the 2. 6 to plan

## 2.6 code-compliant AS/NZS 1170 planning

### 2.6.1 Determine the wind region of your installation site

Region Definition:



Wind regions are pre defined for all of Australia by Australian Standard 1170. The Wind Region has nothing to do with surrounding topography or buildings.

- Most of Australia is designated Region A which indicates a Regional Ultimate Basic Wind Velocity of 45msec.
- Some areas are designated Region B (57msec). Local authorities will advise if this applies in your area.
- Region C areas (66msec) are generally referred to as Cyclonic and are generally limited to northern coastal areas. Most Region C zones end 100km inland.
- Region D (80msec) Australia's worst Cyclonic Region between Carnarvon and Pardoo in Western Australia.

### 2.6.2 Determine the height of the of your installation site

This document provides sufficient information for Grace solar system installation height less than 20 meters. If your installation site is more than 20 meters in height, please contact Grace solar to obtain engineering data to support your installation.

### **2.6.3 Determine the Maximum Rail Support Spacing**

Please use the following table to determine the GD-Rail support spacing for the Triangle Bracket 1 #. This table is suitable for the concrete and metal roof;

<b>Max1970mm Long Panels fixed to Metal Sheet Roof/Concrete Roof</b>		
<b>Installation Height</b>	<b>Region A &amp; B (mm)</b>	<b>Region C &amp; D (mm)</b>
5 Meters	1800	600
10 Meters	1800	600
15 Meters	1500	450
20 Meters	1200	450

- ✓ The above figures are based on modules lengths of up to 1970mm, maximum weight is 15Kg/m<sup>2</sup>
- ✓ The above spacing applies for fixing through thin sheet purlins (greater than 0.75mm thickness) or a minimum embedment of 50mm into timber purlins.
- ✓ Triangle system should be fixed to the purfins or concrete foundation under using two bolts M10 or M12.

### **2. 6.4 Verify acceptable Rail End Overhang**

Rail End Overhang must equal 50 percent or less of foot spacing. Thus, if foot spacing is 1200mm, the Rail End Over hang can be up to 600mm. In this case, two feet can support a rail of as much as 2400mm (1200mm between the feet and 600mm of overhang at each end).

### **2.6.5 Determine Roof slope**

Grasol system can be used for roof slope up to 60 degrees. Please verify the Installation site roof slope should be between 0 degrees and 60 degrees.





### **2.6.6 Determine Roof Installation Roof Areas**

Grasol Tilt System can be installed using those spacing everywhere on the roof.

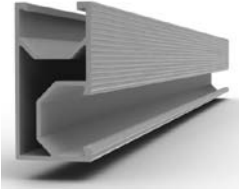

## 2.7 Components



### 2.7.1 Universal Parts

			
GD Rail	GD Rail Splice	Inter Clamp Kit	End Clamp Kit

### 2.7.2 System Parts

	
Triangle Bracket 1# (Folded Pack)	Triangle Bracket 2# (Folded Pack)

### 2.7.3 Accessories

	
Rail Connector Kit	Hex Bolt M10x25 Kit with flat washer x 2

### 3. Installation Steps

**CAUTION:**

Install care while working around the structure during assembly; There could be components that create hazards or obstruct free moment causing serious bodily injury; many at head/eye level. Move slowly and with care around the work area.

#### Step 1: Foundation Construction

Choose the foundation construction solution per **2.1.2**

Comply with the planning to sign out the foundation position and mount the foundation bolts, such as hanger bolts for wood structure roof

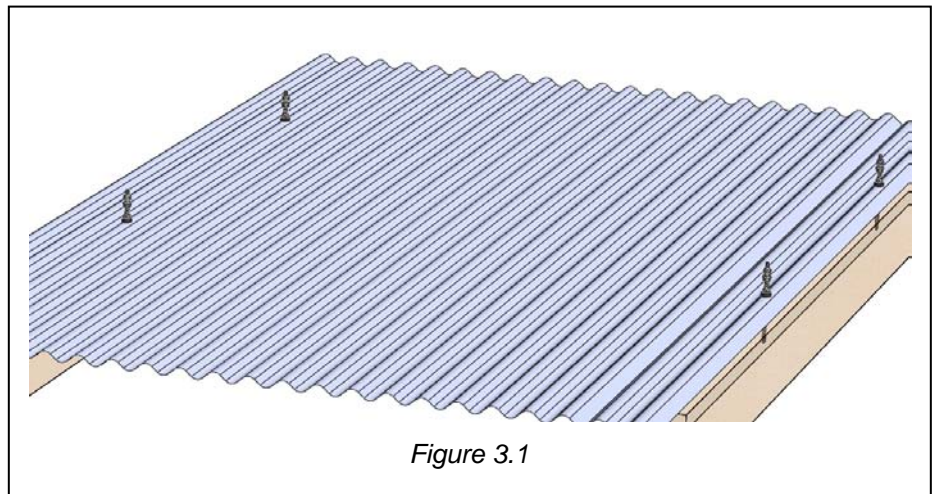

#### Step 2: Install the Triangle Bracket on the Foundation

- a. Open the folded Triangle Bracket as *Figure 3.2* shown. Connect Bottom Support on the foundation bolt.

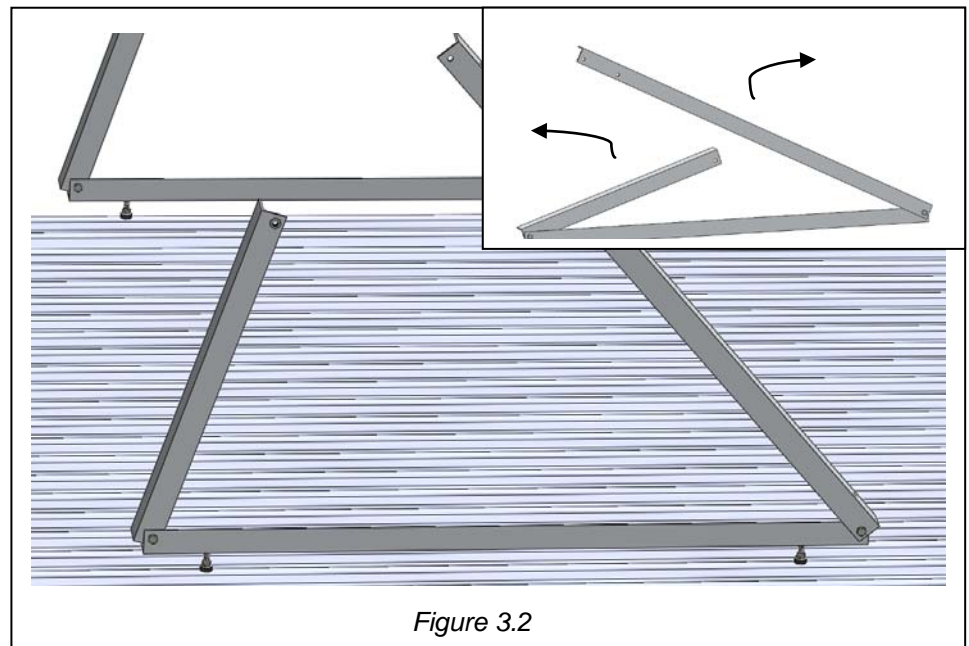

- b. Connect the Beam and the angle support by the Hex Bolt M10x25, flat washerx2 and flange nuts. Please choose the right hole for the angle.

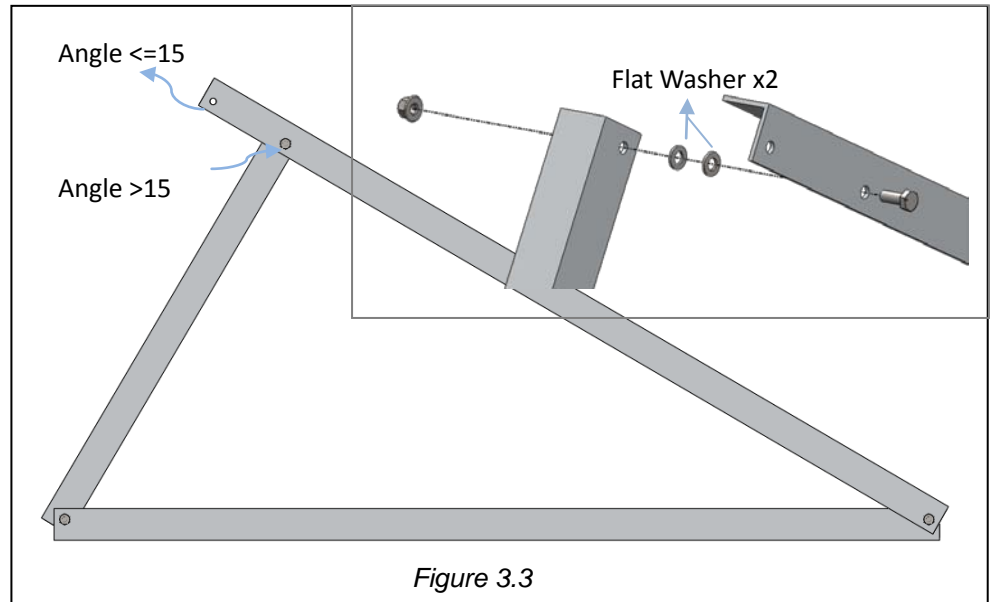

- c. Adjust the foundation bolts to make sure the end of the Bottom Supports is in a line and the top face of the beam is on the same face. Finally, tighten the foundation bolts.

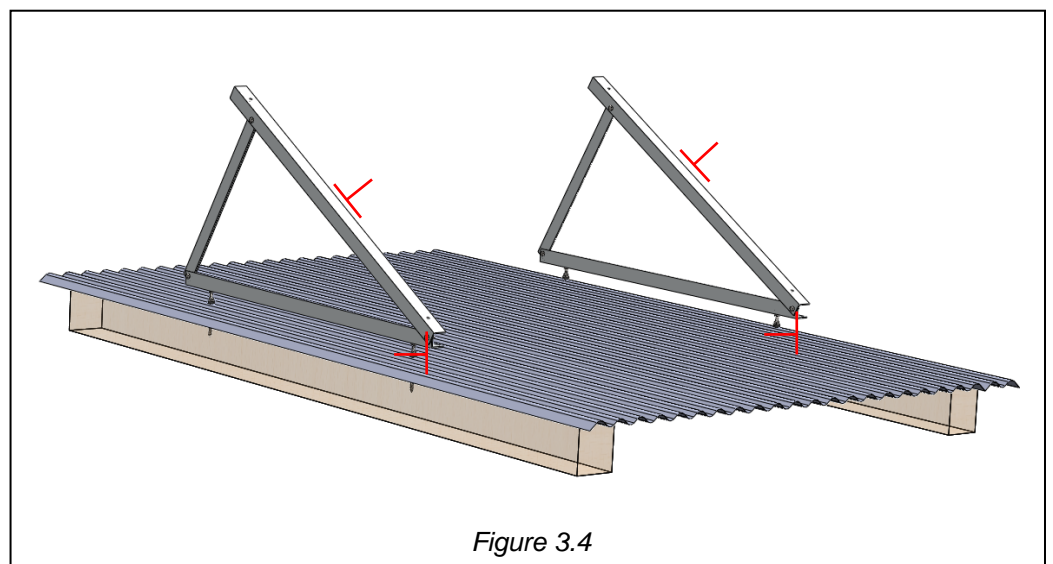

**NOTE:**

The tighten torque for the bolt is listed as below:

M8 Bolt: 11 N\*m

M10 Bolt: 22 N\*m

### Step 3: Install GD Rail on the Triangle Bracket

- a. Place the GD Rail on the Beam, and put the Rail Connector into the side channel of the Rail and fasten the Rail Connector with the Beam by Hexagon Bolt M8x25 with Flange Nut M8. After adjust the end space of the Rail according to the planning, tighten the bolts.

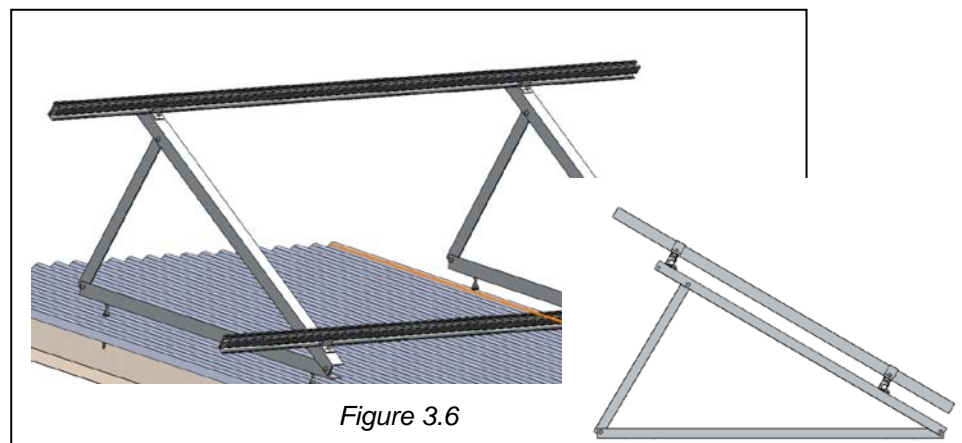
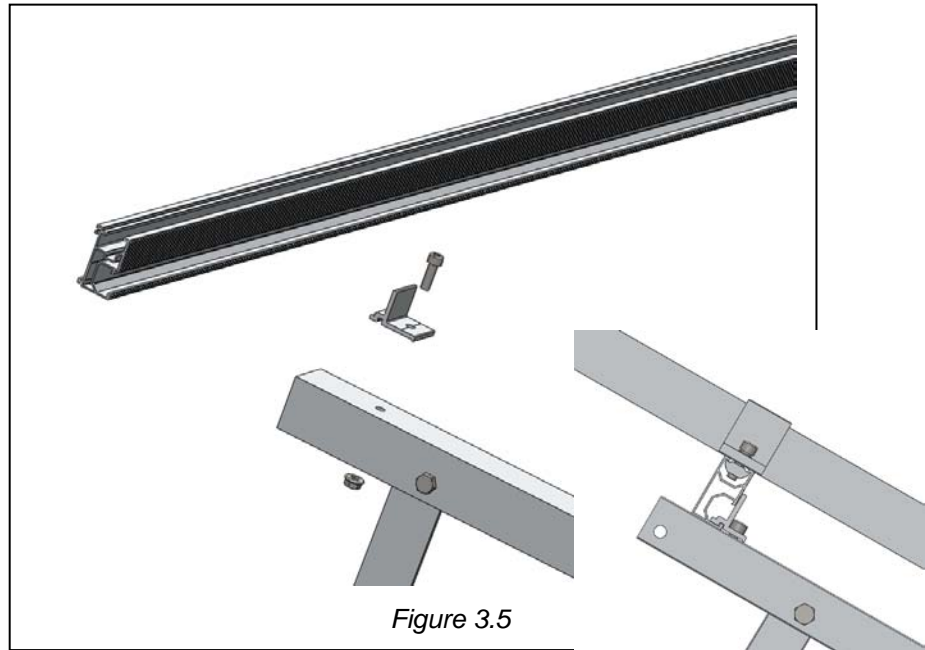

- b. Connect two rails. a. Put the GD Rail Splice into the side channel of the GD Rail about 75mm, then fasten the M8 Bolt. Put the other GD Rail into the other side of the GD Rail Splice and fasten the other M8 bolt.

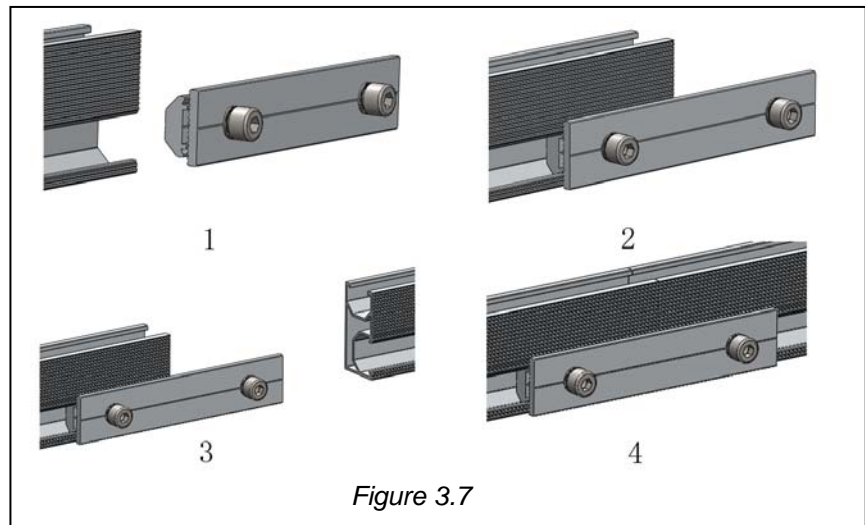

## Step 6: Install the Modules on the GD Rail

Install the modules from one side to the other.

a. Fixing the outer modules by End Clamp

Tilt a certain angle and put the End Clamp Kit into the top channel of the GD Rail. Close to the module end and lock the bolts of the End Clamp Kit.

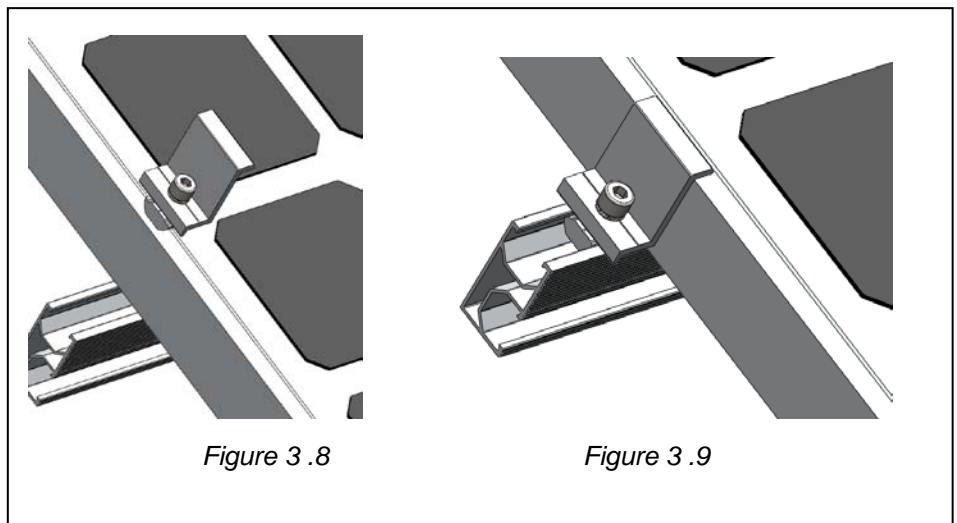

b. Fixing the inner modules by Inter Clamp

Tilt a certain angle and put the Inter Clamp Kit into the top channel of the GD Rail. Align the inter clamp with the modules and insert the other one to close with the other side of the inter clamp. Adjust the modules end to be a line and lock the inter clamp.

**NOTE:**

The Grounding Solution Please is preferred to see Grace Solar Grounding System installation.

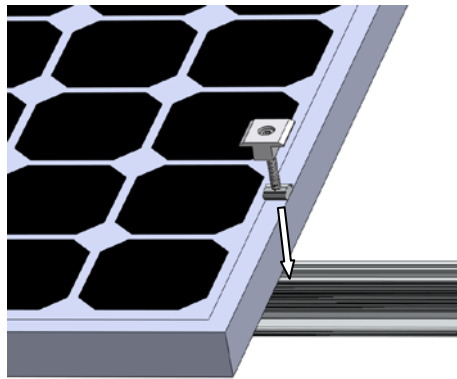

Figure 3 .10

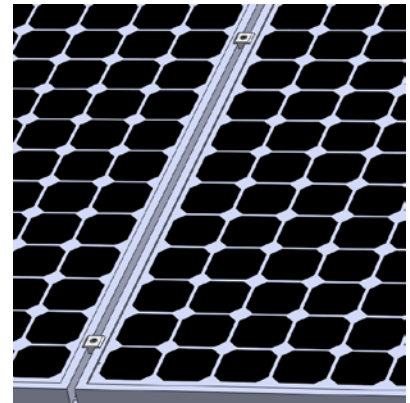

Figure 3 .11

c. Install the other modules

Comply with the step a, b to finish the other modules installation.

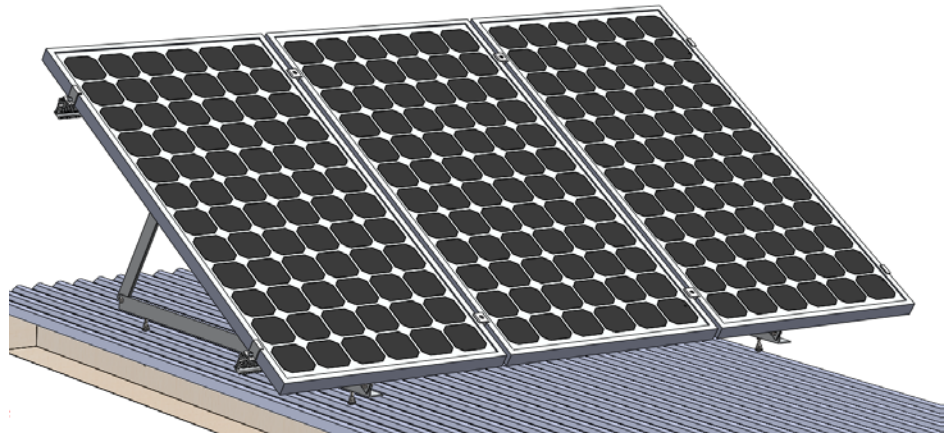

Figure 3 .12